

Chapter 8: Basic Cryptography

- Classical Cryptography
- Public Key Cryptography
- Cryptographic Checksums

Overview

- Classical Cryptography
 - Cæsar cipher
 - Vigènere cipher
 - DES
- Public Key Cryptography
 - Diffie-Hellman
 - RSA
- Cryptographic Checksums
 - HMAC

Cryptosystem

- Quintuple $(\mathcal{E}, \mathcal{D}, \mathcal{M}, \mathcal{K}, \mathcal{C})$
 - \mathcal{M} set of plaintexts
 - \mathcal{K} set of keys
 - \mathcal{C} set of ciphertexts
 - \mathcal{E} set of encryption functions $e: \mathcal{M} \times \mathcal{K} \rightarrow \mathcal{C}$
 - \mathcal{D} set of decryption functions $d: \mathcal{C} \times \mathcal{K} \rightarrow \mathcal{M}$

Example

- Example: Cæsar cipher
 - $\mathcal{M} = \{ \text{sequences of letters} \}$
 - $\mathcal{K} = \{ i \mid i \text{ is an integer and } 0 \leq i \leq 25 \}$
 - $\mathcal{E} = \{ E_k \mid k \in \mathcal{K} \text{ and for all letters } m, \mathop{E_k(m)} = (m + k) \bmod 26 \}$
 - $\mathcal{D} = \{ D_k \mid k \in \mathcal{K} \text{ and for all letters } c, \mathop{D_k(c)} = (26 + c - k) \bmod 26 \}$
 - $\mathcal{C} = \mathcal{M}$

Attacks

- Opponent whose goal is to break cryptosystem is the *adversary*
 - Assume adversary knows algorithm used, but not key
- Three types of attacks:
 - *ciphertext only*: adversary has only ciphertext; goal is to find plaintext, possibly key
 - *known plaintext*: adversary has ciphertext, corresponding plaintext; goal is to find key
 - *chosen plaintext*: adversary may supply plaintexts and obtain corresponding ciphertext; goal is to find key

Basis for Attacks

- Mathematical attacks
 - Based on analysis of underlying mathematics
- Statistical attacks
 - Make assumptions about the distribution of letters, pairs of letters (digrams), triplets of letters (trigrams), *etc.*
 - Called *models of the language*
 - Examine ciphertext, correlate properties with the assumptions.

Classical Cryptography

- Sender, receiver share common key
 - Keys may be the same, or trivial to derive from one another
 - Sometimes called *symmetric cryptography*
- Two basic types
 - Transposition ciphers
 - Substitution ciphers
 - Combinations are called *product ciphers*

Transposition Cipher

- Rearrange letters in plaintext to produce ciphertext
- Example (Rail-Fence Cipher)
 - Plaintext is HELLO WORLD
 - Rearrange as
HLOOL
ELWRD
 - Ciphertext is HLOOL ELWRD

Attacking the Cipher

- Anagramming
 - If 1-gram frequencies match English frequencies, but other n -gram frequencies do not, probably transposition
 - Rearrange letters to form n -grams with highest frequencies

Example

- Ciphertext: HLOOLELWRD
- Frequencies of 2-grams beginning with H
 - HE 0.0305
 - HO 0.0043
 - HL, HW, HR, HD < 0.0010
- Frequencies of 2-grams ending in H
 - WH 0.0026
 - EH, LH, OH, RH, DH ≤ 0.0002
- Implies E follows H

Example

- Arrange so the H and E are adjacent

HE

LL

OW

OR

LD

- Read off across, then down, to get original plaintext

Substitution Ciphers

- Change characters in plaintext to produce ciphertext
- Example (Cæsar cipher)
 - Plaintext is HELLO WORLD
 - Change each letter to the third letter following it (X goes to A, Y to B, Z to C)
 - Key is 3, usually written as letter 'D'
 - Ciphertext is KHOOR ZRUOG

Attacking the Cipher

- Exhaustive search
 - If the key space is small enough, try all possible keys until you find the right one
 - Cæsar cipher has 26 possible keys
- Statistical analysis
 - Compare to 1-gram model of English

Statistical Attack

- Compute frequency of each letter in ciphertext:

G 0.1 H 0.1 K 0.1 O 0.3

R 0.2 U 0.1 Z 0.1

- Apply 1-gram model of English
 - Frequency of characters (1-grams) in English is on next slide

Character Frequencies

a	0.080	h	0.060	n	0.070	t	0.090
b	0.015	i	0.065	o	0.080	u	0.030
c	0.030	j	0.005	p	0.020	v	0.010
d	0.040	k	0.005	q	0.002	w	0.015
e	0.130	l	0.035	r	0.065	x	0.005
f	0.020	m	0.030	s	0.060	y	0.020
g	0.015					z	0.002

Statistical Analysis

- $f(c)$ frequency of character c in ciphertext
- $\varphi(i)$ correlation of frequency of letters in ciphertext with corresponding letters in English, assuming key is i
 - $\varphi(i) = \sum_{0 \leq c \leq 25} f(c)p(c - i)$ so here,
$$\varphi(i) = 0.1p(6 - i) + 0.1p(7 - i) + 0.1p(10 - i) + 0.3p(14 - i) + 0.2p(17 - i) + 0.1p(20 - i) + 0.1p(25 - i)$$
 - $p(x)$ is frequency of character x in English

Correlation: $\varphi(i)$ for $0 \leq i \leq 25$

i	$\varphi(i)$	i	$\varphi(i)$	i	$\varphi(i)$	i	$\varphi(i)$
0	0.0482	7	0.0442	13	0.0520	19	0.0315
1	0.0364	8	0.0202	14	0.0535	20	0.0302
2	0.0410	9	0.0267	15	0.0226	21	0.0517
3	0.0575	10	0.0635	16	0.0322	22	0.0380
4	0.0252	11	0.0262	17	0.0392	23	0.0370
5	0.0190	12	0.0325	18	0.0299	24	0.0316
6	0.0660					25	0.0430

The Result

- Most probable keys, based on φ :
 - $i = 6$, $\varphi(i) = 0.0660$
 - plaintext EBIIIL TLOLA
 - $i = 10$, $\varphi(i) = 0.0635$
 - plaintext AXEEH PHKEW
 - $i = 3$, $\varphi(i) = 0.0575$
 - plaintext HELLO WORLD
 - $i = 14$, $\varphi(i) = 0.0535$
 - plaintext WTAAD LDGAS
- Only English phrase is for $i = 3$
 - That's the key (3 or 'D')

Cæsar's Problem

- Key is too short
 - Can be found by exhaustive search
 - Statistical frequencies not concealed well
 - They look too much like regular English letters
- So make it longer
 - Multiple letters in key
 - Idea is to smooth the statistical frequencies to make cryptanalysis harder

Vigènere CIPHER

- Like Cæsar cipher, but use a phrase
- Example
 - Message THE BOY HAS THE BALL
 - Key VIG
 - Encipher using Cæsar cipher for each letter:

key	VIGVIGVIGVIGVIGV
plain	THEBOYHASTHEBALL
cipher	OPKWECIYOPKWIRG

Relevant Parts of Tableau

	<i>G</i>	<i>I</i>	<i>V</i>
<i>A</i>	G	I	V
<i>B</i>	H	J	W
<i>E</i>	L	M	Z
<i>H</i>	N	P	C
<i>L</i>	R	T	G
<i>O</i>	U	W	J
<i>S</i>	Y	A	N
<i>T</i>	Z	B	O
<i>Y</i>	E	H	T

- Tableau shown has relevant rows, columns only
- Example encipherments:
 - key V, letter T: follow V column down to T row (giving “O”)
 - Key I, letter H: follow I column down to H row (giving “P”)

Useful Terms

- *period*: length of key
 - In earlier example, period is 3
- *tableau*: table used to encipher and decipher
 - Vigènere cipher has key letters on top, plaintext letters on the left
- *polyalphabetic*: the key has several different letters
 - Cæsar cipher is monoalphabetic

Attacking the Cipher

- Approach
 - Establish period; call it n
 - Break message into n parts, each part being enciphered using the same key letter
 - Solve each part
 - You can leverage one part from another
- We will show each step

The Target Cipher

- We want to break this cipher:

ADQYS MIUSB OXKKT MIBHK IZOOO
EQOOG IFBAG KAUMF VVTAA CIDTW
MOCIO EQOOG BMBFV ZGGWP CIEKQ
HSNEW VECNE DLAAV RWKXS VNSVP
HCEUT QOIOF MEGJS WTPCH AJMOC
HIUIX

Establish Period

- Kaskski: *repetitions in the ciphertext occur when characters of the key appear over the same characters in the plaintext*
- Example:

key	VIGVIGVIGVIGVIGV
plain	THEBOYHASTHEBALL
cipher	<u>OPK</u> W <u>E</u> CIY <u>OP</u> KWIRG

Note the key and plaintext line up over the repetitions (underlined). As distance between repetitions is 9, the period is a factor of 9 (that is, 1, 3, or 9)

Repetitions in Example

<i>Letters</i>	<i>Start</i>	<i>End</i>	<i>Distance</i>	<i>Factors</i>
MI	5	15	10	2, 5
OO	22	27	5	5
OEQOOG	24	54	30	2, 3, 5
FV	39	63	24	2, 2, 2, 3
AA	43	87	44	2, 2, 11
MOC	50	122	72	2, 2, 2, 3, 3
QO	56	105	49	7, 7
PC	69	117	48	2, 2, 2, 2, 3
NE	77	83	6	2, 3
SV	94	97	3	3
CH	118	124	6	2, 3

Estimate of Period

- OEQOOG is probably not a coincidence
 - It's too long for that
 - Period may be 1, 2, 3, 5, 6, 10, 15, or 30
- Most others (7/10) have 2 in their factors
- Almost as many (6/10) have 3 in their factors
- Begin with period of $2 \times 3 = 6$

Check on Period

- Index of coincidence is probability that two randomly chosen letters from ciphertext will be the same
- Tabulated for different periods:

1	0.066	3	0.047	5	0.044
2	0.052	4	0.045	10	0.041
Large	0.038				

Compute IC

- $IC = [n (n - 1)]^{-1} \sum_{0 \leq i \leq 25} [F_i (F_i - 1)]$
 - where n is length of ciphertext and F_i the number of times character i occurs in ciphertext
- Here, $IC = 0.043$
 - Indicates a key of slightly more than 5
 - A statistical measure, so it can be in error, but it agrees with the previous estimate (which was 6)

Splitting Into Alphabets

alphabet 1: AIKHOIATTOBGEEERNEOSAI

alphabet 2: DUKKEFUAWEMGKWDWSUFWJU

alphabet 3: QSTIQBMAMQBWQVLKVTMTMI

alphabet 4: YBMZOAFCCOFPHEAXPQEPOX

alphabet 5: SOIOOGVICOVCSVASHOGCC

alphabet 6: MXBOGKVDIGZINNVVCIJHH

- ICs (#1, 0.069; #2, 0.078; #3, 0.078; #4, 0.056; #5, 0.124; #6, 0.043) indicate all alphabets have period 1, except #4 and #6; assume statistics off

Frequency Examination

	A	B	C	D	E	F	G	H	I	J	K	L	M	N	O	P	Q	R	S	T	U	V	W	X	Y	Z
1	3	1	0	0	4	0	1	1	3	0	1	0	0	1	3	0	0	1	1	2	0	0	0	0	0	0
2	1	0	0	2	2	2	1	0	0	1	3	0	1	0	0	0	0	0	1	0	4	0	4	0	0	0
3	1	2	0	0	0	0	0	2	0	1	1	4	0	0	0	4	0	1	3	0	2	1	0	0	0	0
4	2	1	1	0	2	2	0	1	0	0	0	0	1	0	4	3	1	0	0	0	0	0	0	2	1	1
5	1	0	5	0	0	0	2	1	2	0	0	0	0	0	5	0	0	0	3	0	0	2	0	0	0	0
6	0	1	1	1	0	0	2	2	3	1	1	0	1	2	1	0	0	0	0	0	0	3	0	1	0	1

Letter frequencies are (H high, M medium, L low):

HMMMHHMMHHMMMMHHMLHHMLLLLLL

Begin Decryption

- First matches characteristics of unshifted alphabet
- Third matches if I shifted to A
- Sixth matches if V shifted to A
- Substitute into ciphertext (bold are substitutions)

ADIYS RIUKB OCKKL MIGHK AZOTO
EIOOL IFTAG PAUEF VATAS CIITW
EOCNO EIOOL BMTFV EGGOP CNEKI
HSSEW NECSE DDAAA RWCXS ANSNP
HHEUL QONOF EEGOS WLPCM AJEOC
MIUAX

Look For Clues

- **AJE** in last line suggests “are”, meaning second alphabet maps A into S:

ALIYS RICKB OCKSL MIGHS AZOTO
MIOOL INTAG PACEF VATIS CIITE
EOCNO MIOOL BUTFV EGOOP CNESI
HSSEE NECSE LDAAA RECXS ANANP
HHECL QONON EEGOS ELPCM AREOC
MICAX

Next Alphabet

- **MICAX** in last line suggests “mical” (a common ending for an adjective), meaning fourth alphabet maps O into A:

ALIMS RICKP OCKSL AIGHS ANOTO
MICOL INTOG PACET VATIS QIITE
ECCNO MICOL BUTTV EGOOD CNESI
VSSEE NSCSE LDOAA RECLS ANAND
HHECL EONON ESGOS ELDCM ARECC
MICAL

Got It!

- QI means that U maps into I, as Q is always followed by U:

**ALIME RICKP ACKSL AUGHS ANATO
MICAL INTOS PACET HATIS QUITE
ECONO MICAL BUTTH EGOOD ONESI
VESEE NSOSE LDOMA RECLE ANAND
THECL EANON ESSOS ELDOM ARECO
MICAL**

One-Time Pad

- A Vigenère cipher with a random key at least as long as the message
 - Provably unbreakable
 - Why? Look at ciphertext DXQR. Equally likely to correspond to plaintext DOIT (key AJIY) and to plaintext DONT (key AJDY) and any other 4 letters
 - Warning: keys *must* be random, or you can attack the cipher by trying to regenerate the key
 - Approximations, such as using pseudorandom number generators to generate keys, are *not* random

Overview of the DES

- A block cipher:
 - encrypts blocks of 64 bits using a 64 bit key
 - outputs 64 bits of ciphertext
- A product cipher
 - basic unit is the bit
 - performs both substitution and transposition (permutation) on the bits
- Cipher consists of 16 rounds (iterations) each with a round key generated from the user-supplied key

Generation of Round Keys

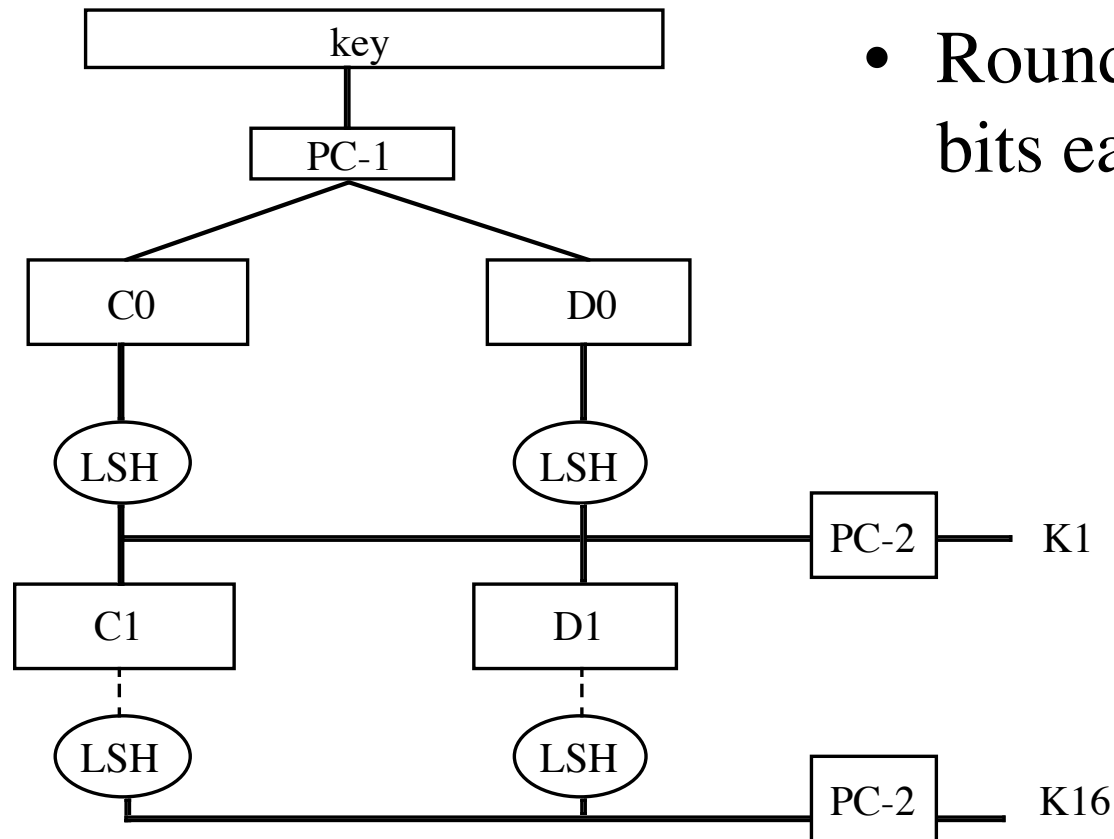

- Round keys are 48 bits each

Encipherment

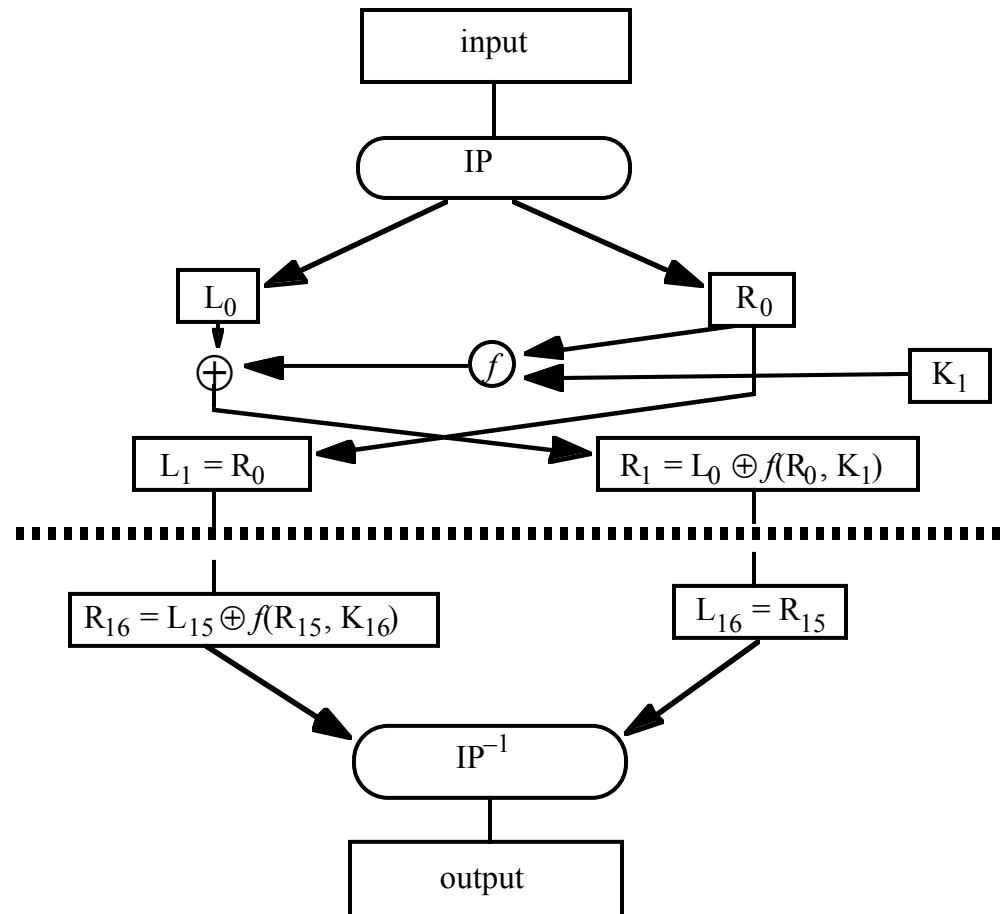

The f Function

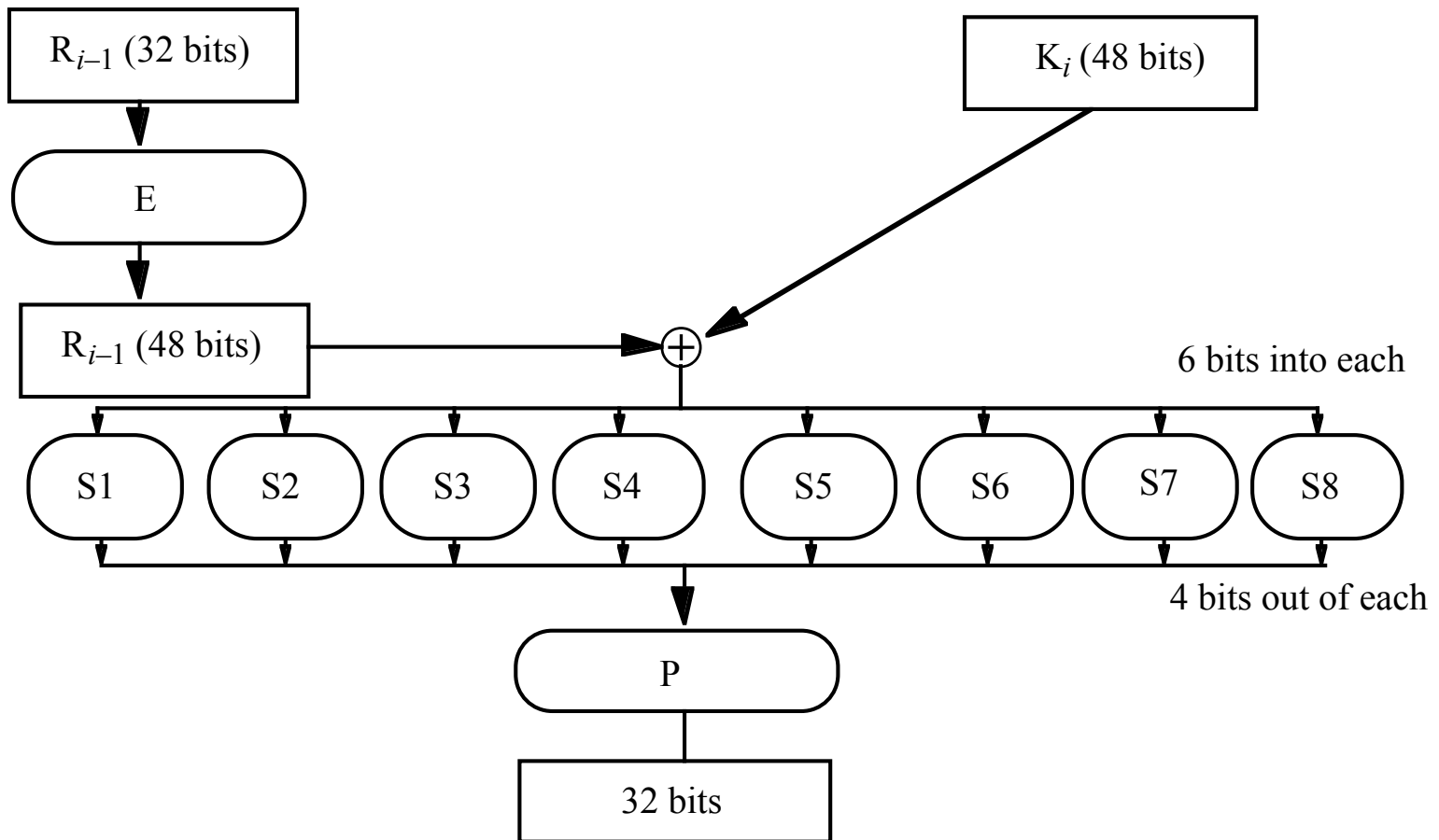

Controversy

- Considered too weak
 - Diffie, Hellman said in a few years technology would allow DES to be broken in days
 - Design using 1999 technology published
 - Design decisions not public
 - S-boxes may have backdoors

Undesirable Properties

- 4 weak keys
 - They are their own inverses
- 12 semi-weak keys
 - Each has another semi-weak key as inverse
- Complementation property
 - $\text{DES}_k(m) = c \Rightarrow \text{DES}_k(m') = c'$
- S-boxes exhibit irregular properties
 - Distribution of odd, even numbers non-random
 - Outputs of fourth box depends on input to third box

Differential Cryptanalysis

- A chosen ciphertext attack
 - Requires 2^{47} plaintext, ciphertext pairs
- Revealed several properties
 - Small changes in S-boxes reduce the number of pairs needed
 - Making every bit of the round keys independent does not impede attack
- Linear cryptanalysis improves result
 - Requires 2^{43} plaintext, ciphertext pairs

DES Modes

- Electronic Code Book Mode (ECB)
 - Encipher each block independently
- Cipher Block Chaining Mode (CBC)
 - Xor each block with previous ciphertext block
 - Requires an initialization vector for the first one
- Encrypt-Decrypt-Encrypt Mode (2 keys: k, k')
 - $c = \text{DES}_k(\text{DES}_{k'}^{-1}(\text{DES}_k(m)))$
- Encrypt-Encrypt-Encrypt Mode (3 keys: k, k', k'')
 - $c = \text{DES}_k(\text{DES}_{k'}(\text{DES}_{k''}(m)))$

CBC Mode Encryption

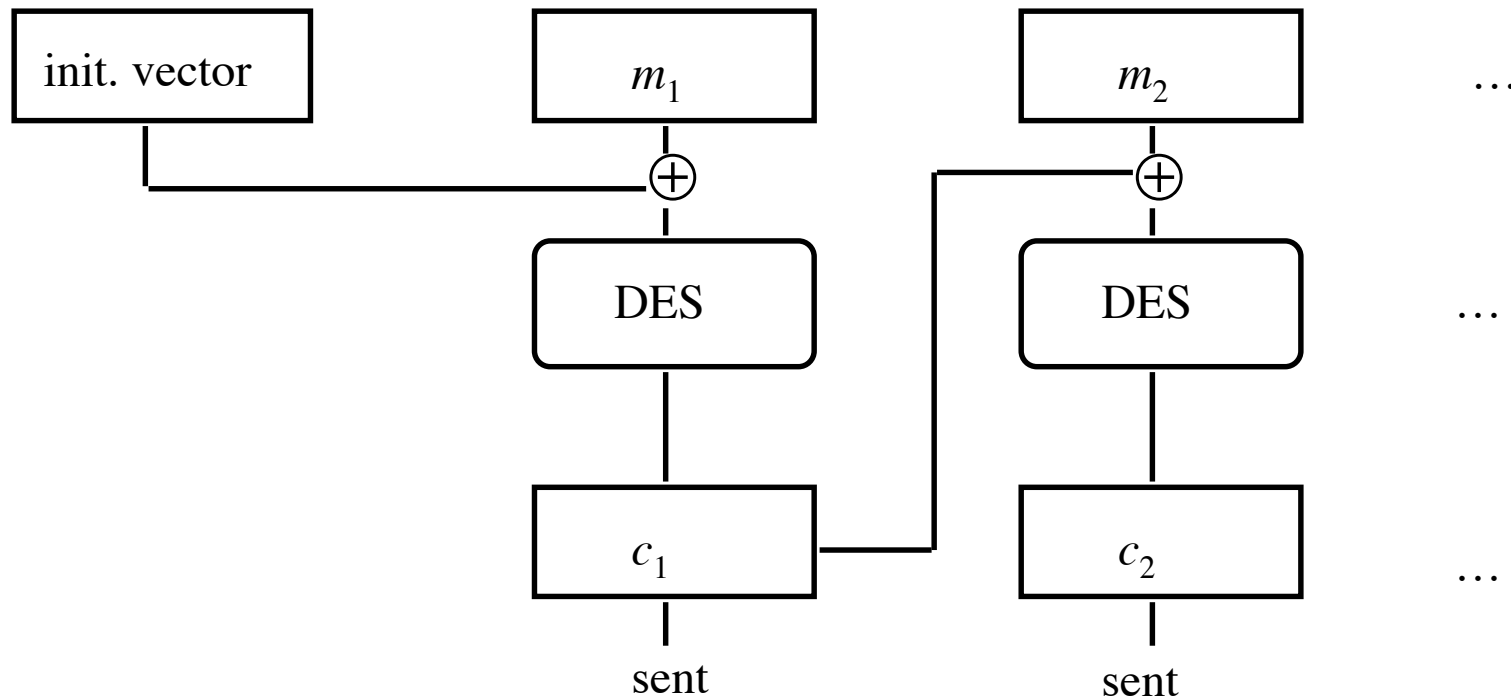

CBC Mode Decryption

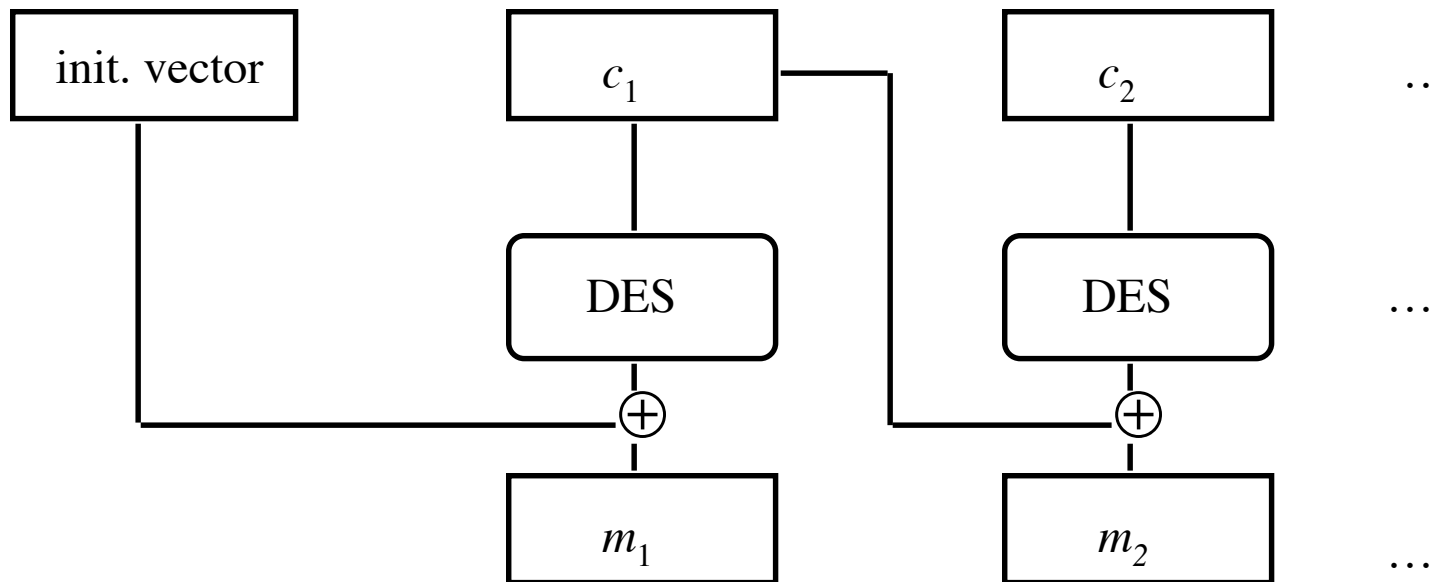

Self-Healing Property

- Initial message
 - 3231343336353837 3231343336353837
3231343336353837 3231343336353837
- Received as (underlined 4c should be 4b)
 - ef7c4cb2b4ce6f3b f6266e3a97af0e2c
746ab9a6308f4256 33e60b451b09603d
- Which decrypts to
 - efca61e19f4836f1 3231333336353837
3231343336353837 3231343336353837
 - Incorrect bytes underlined
 - Plaintext “heals” after 2 blocks

Current Status of DES

- Design for computer system, associated software that could break any DES-enciphered message in a few days published in 1998
- Several challenges to break DES messages solved using distributed computing
- NIST selected Rijndael as Advanced Encryption Standard, successor to DES
 - Designed to withstand attacks that were successful on DES

Public Key Cryptography

- Two keys
 - *Private key* known only to individual
 - *Public key* available to anyone
 - Public key, private key inverses
- Idea
 - Confidentiality: encipher using public key, decipher using private key
 - Integrity/authentication: encipher using private key, decipher using public one

Requirements

1. It must be computationally easy to encipher or decipher a message given the appropriate key
2. It must be computationally infeasible to derive the private key from the public key
3. It must be computationally infeasible to determine the private key from a chosen plaintext attack

RSA

- Exponentiation cipher
- Relies on the difficulty of determining the number of numbers relatively prime to a large integer n

Background

- Totient function $\phi(n)$
 - Number of positive integers less than n and relatively prime to n
 - *Relatively prime* means with no factors in common with n
- Example: $\phi(10) = 4$
 - 1, 3, 7, 9 are relatively prime to 10
- Example: $\phi(21) = 12$
 - 1, 2, 4, 5, 8, 10, 11, 13, 16, 17, 19, 20 are relatively prime to 21

Algorithm

- Choose two large prime numbers p, q
 - Let $n = pq$; then $\phi(n) = (p-1)(q-1)$
 - Choose $e < n$ such that e is relatively prime to $\phi(n)$.
 - Compute d such that $ed \bmod \phi(n) = 1$
- Public key: (e, n) ; private key: d
- Encipher: $c = m^e \bmod n$
- Decipher: $m = c^d \bmod n$

Example: Confidentiality

- Take $p = 7$, $q = 11$, so $n = 77$ and $\phi(n) = 60$
- Alice chooses $e = 17$, making $d = 53$
- Bob wants to send Alice secret message HELLO
(07 04 11 11 14)
 - $07^{17} \bmod 77 = 28$
 - $04^{17} \bmod 77 = 16$
 - $11^{17} \bmod 77 = 44$
 - $11^{17} \bmod 77 = 44$
 - $14^{17} \bmod 77 = 42$
- Bob sends 28 16 44 44 42

Example

- Alice receives 28 16 44 44 42
- Alice uses private key, $d = 53$, to decrypt message:
 - $28^{53} \bmod 77 = 07$
 - $16^{53} \bmod 77 = 04$
 - $44^{53} \bmod 77 = 11$
 - $44^{53} \bmod 77 = 11$
 - $42^{53} \bmod 77 = 14$
- Alice translates message to letters to read HELLO
 - No one else could read it, as only Alice knows her private key and that is needed for decryption

Example:

Integrity/Authentication

- Take $p = 7$, $q = 11$, so $n = 77$ and $\phi(n) = 60$
- Alice chooses $e = 17$, making $d = 53$
- Alice wants to send Bob message HELLO (07 04 11 11 14) so Bob knows it is what Alice sent (no changes in transit, and authenticated)
 - $07^{53} \bmod 77 = 35$
 - $04^{53} \bmod 77 = 09$
 - $11^{53} \bmod 77 = 44$
 - $11^{53} \bmod 77 = 44$
 - $14^{53} \bmod 77 = 49$
- Alice sends 35 09 44 44 49

Example

- Bob receives 35 09 44 44 49
- Bob uses Alice's public key, $e = 17$, $n = 77$, to decrypt message:
 - $35^{17} \bmod 77 = 07$
 - $09^{17} \bmod 77 = 04$
 - $44^{17} \bmod 77 = 11$
 - $44^{17} \bmod 77 = 11$
 - $49^{17} \bmod 77 = 14$
- Bob translates message to letters to read HELLO
 - Alice sent it as only she knows her private key, so no one else could have enciphered it
 - If (enciphered) message's blocks (letters) altered in transit, would not decrypt properly

Example: Both

- Alice wants to send Bob message HELLO both enciphered and authenticated (integrity-checked)
 - Alice's keys: public (17, 77); private: 53
 - Bob's keys: public: (37, 77); private: 13
- Alice enciphers HELLO (07 04 11 11 14):
 - $(07^{53} \bmod 77)^{37} \bmod 77 = 07$
 - $(04^{53} \bmod 77)^{37} \bmod 77 = 37$
 - $(11^{53} \bmod 77)^{37} \bmod 77 = 44$
 - $(11^{53} \bmod 77)^{37} \bmod 77 = 44$
 - $(14^{53} \bmod 77)^{37} \bmod 77 = 14$
- Alice sends 07 37 44 44 14

Security Services

- Confidentiality
 - Only the owner of the private key knows it, so text enciphered with public key cannot be read by anyone except the owner of the private key
- Authentication
 - Only the owner of the private key knows it, so text enciphered with private key must have been generated by the owner

More Security Services

- Integrity
 - Enciphered letters cannot be changed undetectably without knowing private key
- Non-Repudiation
 - Message enciphered with private key came from someone who knew it

Warnings

- Encipher message in blocks considerably larger than the examples here
 - If 1 character per block, RSA can be broken using statistical attacks (just like classical cryptosystems)
 - Attacker cannot alter letters, but can rearrange them and alter message meaning
 - Example: reverse enciphered message of text ON to get NO

Cryptographic Checksums

- Mathematical function to generate a set of k bits from a set of n bits (where $k \leq n$).
 - k is smaller than n except in unusual circumstances
- Example: ASCII parity bit
 - ASCII has 7 bits; 8th bit is “parity”
 - Even parity: even number of 1 bits
 - Odd parity: odd number of 1 bits

Example Use

- Bob receives “10111101” as bits.
 - Sender is using even parity; 6 1 bits, so character was received correctly
 - Note: could be garbled, but 2 bits would need to have been changed to preserve parity
 - Sender is using odd parity; even number of 1 bits, so character was not received correctly

Definition

- Cryptographic checksum $h: A \rightarrow B$:
 1. For any $x \in A$, $h(x)$ is easy to compute
 2. For any $y \in B$, it is computationally infeasible to find $x \in A$ such that $h(x) = y$
 3. It is computationally infeasible to find two inputs $x, x' \in A$ such that $x \neq x'$ and $h(x) = h(x')$
 - Alternate form (stronger): Given any $x \in A$, it is computationally infeasible to find a different $x' \in A$ such that $h(x) = h(x')$.

Collisions

- If $x \neq x'$ and $h(x) = h(x')$, x and x' are a *collision*
 - Pigeonhole principle: if there are n containers for $n+1$ objects, then at least one container will have 2 objects in it.
 - Application: if there are 32 files and 8 possible cryptographic checksum values, at least one value corresponds to at least 4 files

Keys

- Keyed cryptographic checksum: requires cryptographic key
 - DES in chaining mode: encipher message, use last n bits. Requires a key to encipher, so it is a keyed cryptographic checksum.
- Keyless cryptographic checksum: requires no cryptographic key
 - MD5 and SHA-1 are best known; others include MD4, HAVAL, and Snefru

HMAC

- Make keyed cryptographic checksums from keyless cryptographic checksums
- h keyless cryptographic checksum function that takes data in blocks of b bytes and outputs blocks of l bytes. k' is cryptographic key of length b bytes
 - If short, pad with 0 bytes; if long, hash to length b
- $ipad$ is 00110110 repeated b times
- $opad$ is 01011100 repeated b times
- $HMAC-h(k, m) = h(k' \oplus opad \parallel h(k' \oplus ipad \parallel m))$
 - \oplus exclusive or, \parallel concatenation

Key Points

- Two main types of cryptosystems: classical and public key
- Classical cryptosystems encipher and decipher using the same key
 - Or one key is easily derived from the other
- Public key cryptosystems encipher and decipher using different keys
 - Computationally infeasible to derive one from the other
- Cryptographic checksums provide a check on integrity